

Abstract

This application note discusses methodology for testing analog amplifiers designed to process DMT (discrete multitone) waveforms, also known as OFDM (orthogonal frequency division multiplexing) waveforms. There is a brief introduction of the DMT waveform where it's pointed out that a troublesome characteristic of the DMT waveform is a probabilistically large peak to average amplitude ratio. The application note then goes on to derive the probability density distribution for the DMT peak to average ratio (PAR) in preparation for presenting a test methodology. It then discusses the concept of the MTPR (multitone power ratio) test, which consists of a plethora of frequency domain impulses, uniformly spaced over the bandwidth of interest, with the characteristic that periodically a frequency impulse is "missing", giving the appearance of a "spectral notch". The object of the test is to pass this MTPR test waveform through the amplifier under test and observe the depth of the "notches" at the output of the amplifier, which will be "filled-in" due to any amplifier nonlinearities. Further discussions go on to state that such testing should be done with several MTPR test vectors, each with a unique peak to average ratio, and the composite MTPR of the amplifier is the probability weighted sum of the individual MTPR responses.

1.0 Introduction

The testing of analog amplifiers designed for use with a DMT waveform presents challenges due to the potentially large peak to average ratio (PAR) (See Note 1). Specifically, while the amplifier may have sufficient dynamic range to handle the average signal level, it may lack "headroom" to pass the signal peak amplitude without clipping or compressing. This potentially large peak to average ratio (PAR) is somewhat problematic of multi-carrier modulation schemes and does not exist to the same extent for single carrier systems. The required test methodology for waveforms that exhibit large PARs should be treated somewhat differently than that for single carrier systems where the PAR is more deterministic. This type of testing is the subject of this Application Note.

2.0 The DMT Waveform

The idea behind DMT (discrete multitone modulation) is the partitioning of the available bandwidth into frequency subbands, or bins, and assigning a low baud rate modulated carrier to each bin center. The rationale is that over the subband bandwidth, the channel looks relatively benign and hence will require minimal equalization, which in turn simplifies implementation. This frequency bin approach is a natural for modulation by the inverse FFT and demodulation by the FFT, which gives rise to a particular subset of DMT called OFDM (orthogonal frequency division multiplexing). Basically, OFDM is the conversion of a modulating data vector, representing modulation symbols for each of the parallel frequency tones, into a time domain sequence for transmission over a channel terminating in an OFDM demodulator for extraction of the data vector. Figure 1 shows a block diagram of the basic DMT/OFDM structure where p_i and q_i represent the modulating/demodulating tones.

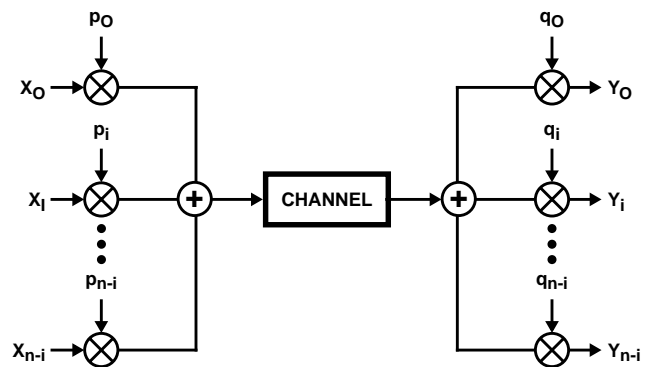

FIGURE 1. DMT BASIC STRUCTURE

The drawback to DMT in general is a bothersome peak to average ratio associated with the channel waveform due to possible subcarrier instantaneous summation. For ADSL, with a possible 256 carriers, this peak can be obviously large, but fortunately does not occur very often. The theoretical limit on the PAR, given constant envelope signaling on each DMT carrier, is $10 \cdot \log_{10}(M)$, where M represents the number of DMT carriers. Fortunately, this worst case condition seldom happens. For the case where the number of carriers is reasonably large, the probability distribution on a per sample basis is Gaussian distributed based on the central limit theorem, a fact which is germane to the next topic.

NOTE:

1. Peak to average ratio (PAR) is also known as the "crest factor".

3.0 The DMT Peak to Average PDF

We now consider the probability of a given PAR occurring assuming that the generating waveform is noise like with a Gaussian distribution. As previously mentioned, this assumption is justified by the central limit theorem [4]. The expression for the peak to average probability for a particular peak value is given by Equation 1 (derived in the appendix) as purview

$$P(x) = \frac{2N}{\sqrt{2\pi}} e^{-\frac{x^2}{2}} [1 - 2Q(x)]^N B \quad (\text{EQ. 1})$$

where N is the number of points in the FFT (assuming FFT based processing - see Section 2.0), B is the interval of interest about the peak value x in question (see Appendix), and Q is the traditional normal distribution probability function. Equation 1 defines the probability distribution and Figure 2 plots this result for various values of x for an ADSL FFT (See note 2), which has a block length of 512 points [1]. It was found that the most likely PAR for ADSL is slightly greater than three.

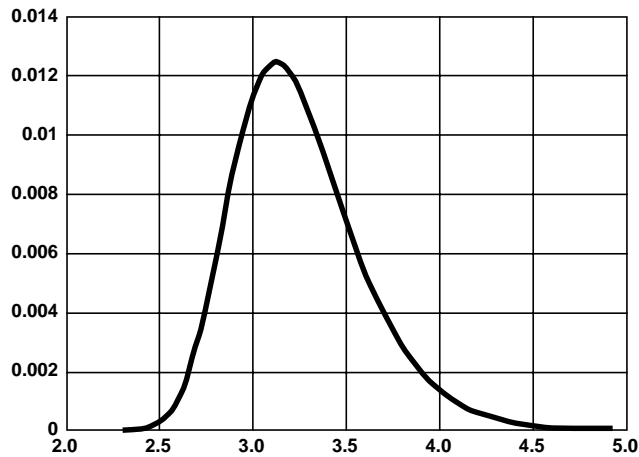

FIGURE 2. THEORETICAL CREST FACTOR HISTOGRAM

4.0 Traditional Test Methods

Traditional quantification of an amplifier's linearity has evolved around the concept of total harmonic distortion (THD), mainly for simplicity reasons. In this test a single tone is applied at the input of the amplifier, and at the output the ratio between the desired signal and all distortion components is measured. This measure of distortion (using a single tone) is at best an approximation for any modulated signal. One perhaps can make an argument that the THD technique somewhat represents the narrow-band single carrier case but it is felt that it is totally unacceptable for the multi-carrier case.

NOTE:

- 2. ADSL - Asymmetric Digital Subscriber Line.

5.0 The MTPR Test

Modifying a classic technique from FDM (see note 3) analog technology for testing system linearity, we define the concept of the MTPR (multitone power ratio) test. This test consists of a plethora of frequency domain impulses, uniformly spaced over a bandwidth of interest, with the characteristic that periodically a frequency impulse is "missing" giving the appearance of a spectral notch. The time series representation of this waveform for the case where every 16th tone is absent is given as

$$s(k) = \sum_i^L \cos(\Omega_i k + \theta_i) \quad i \neq 16, 32, \text{ etc.} \quad (\text{EQ. 2})$$

where L = 256 for ADSL, $\Omega_i = 2\pi i/L$ and the term θ_i represents the starting phase of the i^{th} tone (see note 4).

Figure 3 represents the spectrum of this test vector. Notice that the comb spectrum has suppressed tones located periodically in the spectrum. The frequency impulses are separated by the DMT carrier spacing [2] and each carrier of the comb is given a controlled starting phase θ_i [3] to constrain the PAR. Specifically, each tone's starting phase is adjusted to establish a desired PAR (see note 5) and the average signal level of the test vector is adjusted for a certain "backoff level" below full scale.

The object of the test is to pass this test waveform through the amplifier under test and observe at the output the depth of the "notches" with respect to the level of the adjacent carriers. Factors that contribute to "filling-in" of the output notches are the intermodulation characteristics of the analog amplifier and the residual noise floor. It is felt that this testing technique better represents the actual scenario present in the case of the DMT/OFDM spectrum, where it is important to maintain a high signal to distortion ratio in each of the frequency bins. Typical aggregate MTPR requirements for ADSL are on the order of 65dB [1] (i.e. notches need to have a depth of at least 65dB).

The implementation of this test is probably more efficiently performed via DSP processing by storing the test vector of Equation 2, with a known PAR value, in a high speed memory buffer and repeatedly playing the signal out via a digital-to-analog interface. Typically, the output of the amplifier is also digitally processed, via an analog-to-digital interface, for ease of analysis. Figure 4 shows the block diagram of such a test setup.

NOTES:

- 3. Frequency Division Multiplexing.
- 4. As pointed out in Section 2.0 of this Application Note, a more efficient technique for generation of this time series is via the inverse FFT.
- 5. To illustrate, the worst case PAR occurs when summing cosine waveforms all with zero starting phase. By scrambling the starting phase of each term in the summation, we can establish a desired PAR between deterministic limits.

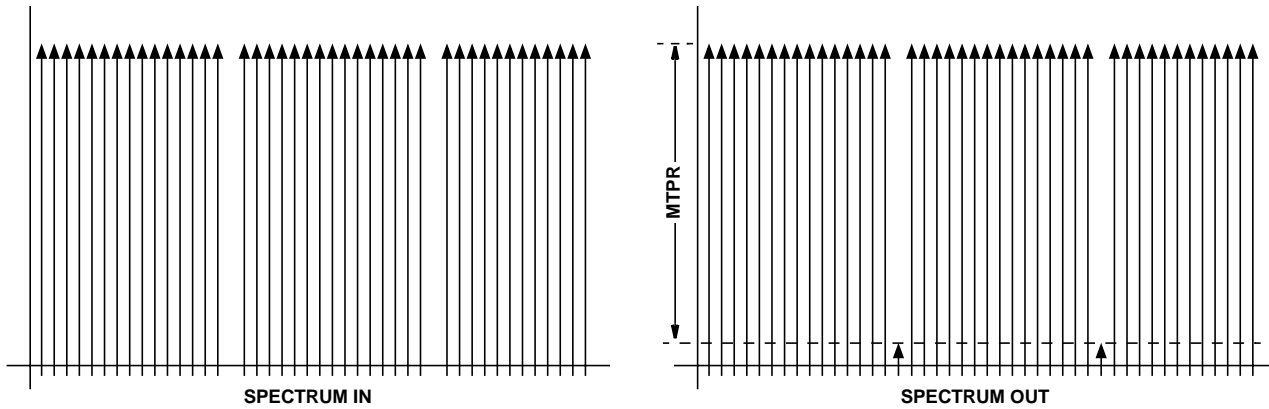

FIGURE 3. MTPR DEFINITION

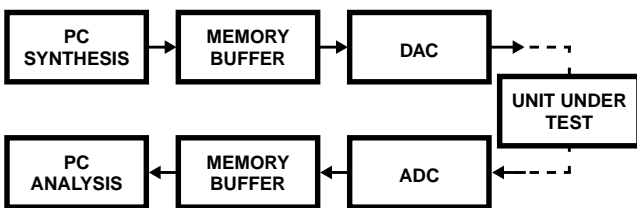

FIGURE 4. TEST SETUP BLOCK DIAGRAM

6.0 Probability Weighted MTPR Test

We are suggesting that the overall multitone power ratio (MTPR), as specified at the DMT system level, represents a probability weighted number over a specified PAR range rather than a MTPR that needs to be achieved at the worst case PAR. For example, suppose that an ADSL DMT (N = 512) (see note 6) system level requirement for a particular amplifier specifies a signal to intermodulation ratio of 65dB for any given frequency bin with the probability of a “clip” (hard limit) of 10^{-7} . From Equation 1, we find the value of x that corresponds to the clip probability, but this only determines where the amplifier clips and does not necessarily describe the linearity of the amplifier. For example, if the amplifier were designed to maintain a THD of 65dB for an equivalent sinewave stimulus with a sinusoidal peak value near the clipping level, then the amplifier would be over designed. Rather, we need to consider the statistical nature of the DMT signal while testing the amplifier linearity. Specifically, those peak values that infrequently occur will not significantly contribute to the intermodulation noise level. Taking this viewpoint will result in a more optimal test of the amplifier and hence a more optimal amplifier design.

To reiterate, designing a line driver to handle a peak that infrequently occurs may lead to a suboptimal design from a cost point of view. We would certainly want to have a design that can handle a high percentage of the peaks with very low distortion, but perhaps we would concede to have low probability peaks suffer a slight degradation in linearity in order to reduce the manufacturing costs (i.e., a weak nonlinearity as opposed to a hard limit) (see note 7).

We now state the following assumptions in order to establish the framework for the probability weighted testing.

1. All MTPR test vectors will have a PAR that is less than or equal to the specified clipping amplitude.
 - For example, for ADSL the PAR for a clip probability of 10^{-7} is about 5.3. This establishes the maximum PAR we will generate.
2. All MTPR test vectors will be within the dynamic range of the amplifier (i.e., no clipping at the amplifier output).
 - The maximum PAR should be confined to be within the dynamic range of the amplifier. For example, for ADSL the PAR for a clip probability of 10^{-7} is about 5.3, thus we adjust the amplitude of the test signal at the input of the amplifier (i.e., lower average value) so that the output of the amplifier passes this 5.3 PAR without clipping.
3. All MTPR test vectors (waveforms) will have a PAR less than the assumed maximum (for which the amplifier was designed to handle).
 - The amplifier may exhibit a weak nonlinearity over this range of PAR but it must not have a “hard” limit.
4. All MTPR testing may be done with repetitive test vectors; that is, continuous replaying of a single unique PAR test vector.
 - This assumption allows us to use averaging techniques to reduce measurement error. It also facilitates testing by allowing us to work with “continuous” waveforms instead of signal bursts.

NOTES:

6. Generating 256 real tones via an IFFT requires an input vector of 512 Hermitian symmetric points.
7. One could argue that during the duration of the transmitter symbol containing the high PAR, and because of the amplifier weak nonlinearity, this particular symbol will require assistance from forward error control (FEC) to prevent a degradation in the BER.

5. After measuring the individual MTPRs for each unique PAR input test vector, the overall composite average MTPR will be calculated as

$$\text{MTPR} = \sum(\text{MTPR}_i * P_i) \quad \forall "i" \quad (\text{EQ. 3})$$

where P_i = probability of the PAR for the i^{th} measurement (reference Equation 1).

To illustrate the process, Figure 5 shows a representative MTPR vs PAR measurement of an amplifier prior to calculation of the average MTPR by probability weighting and summation (i.e., averaging). To summarize Figure 5, we show the amplifiers MTPR capability vs several input test vector PARs. The scatter plot shows that the amplifier's MTPR starts to degrade as the PAR approaches the specified limit. Again, we are not talking about a strong amplifier nonlinearity, but rather about a weak nonlinearity which is proportional to the PAR value. However - to reiterate - because the probability of these extreme PAR values is sharply decreasing, the overall system MTPR degradation due to large PAR values is slight. This is expressed by the probability averaging (Equation 3) utilizing the PAR distribution (Equation 1).

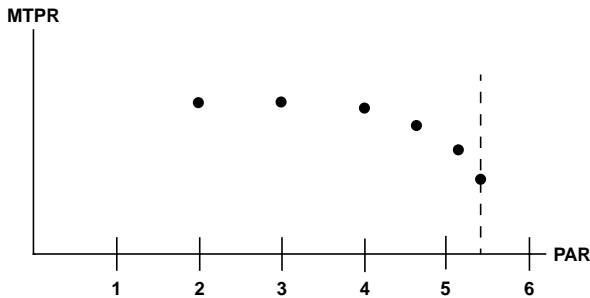

FIGURE 5. PAR DEPENDENT MTPR

7.0 Conclusions

It is postulated that when a DMT system specification specifies a required MTPR with a given PAR clipping level, what is being specified is an average PAR requirement and not a worst case requirement. That is, for a given range of PAR (i.e., dynamic range), the system designer wants a certain average MTPR performance when the input DMT waveform represents randomly modulated data. As shown in this Application Note, this randomly modulated DMT waveform will have a PAR, for any given transmit symbol, that is not uniformly distributed. That is, over the given PAR range, the probability of a given peak value occurring near the range extremes, for any transmitted symbol, is statistically less likely. Thus, the hardware designer can design an amplifier that exhibits superior performance for the most probable PAR values with an allowable *slight* degradation in performance for those PARs that are the least likely. This will result in a more optimal design. The important point is that when the measured MTPR's over the required PAR range are weighted with the PAR probability density, we

will end up with an overall performance that meets the required system level MTPR number in a more optimal manner than a simple worst case design. This will prevent over designing the analog hardware.

References

- [1] Asymmetrical Digital Subscriber Line (ADSL) Metallic Interface, ANSI T1.413-1995.
- [2] J.A.C. Bingham, "Multicarrier Modulation for Data Transmission: An Idea Whose Time Has Come", IEEE Communications Magazine, pp. 5-14, May 1990.
- [3] D.R. Gimlin and C.R. Patisaul, "On Minimizing the Peak-To-Average Power Ratio for the Sum of N Sinusoids", IEEE TCOM, p. 631-635, April 1993.
- [4] N. Al-Dhahir and J. Cioffi, "On the Uniform ADC Bit Precision and Clip Level Computation for a Gaussian Signal", IEEE Trans. Sig. Proc., p. 434-438, Feb. 1996.

Appendix

Assume that we are using N point IFFTs to generate a real waveform (N/2 unique samples with the remaining samples exhibiting Hermitian symmetry). Assume also that each tonal carrier can be modulated with a very high order random QAM signal such that any given tonal carrier appears to be modulated with quadriphase white noise. From the central limit theorem, we assume that the composite time domain waveform can be modeled as white Gaussian noise; thus, we will start our analysis by assuming that the Q function is an appropriate description of the time domain waveform on a sample by sample basis. The Q(x) function with zero mean and unit variance is defined in Equation A1 along with the Erfc(x) and the Erf(x) functions.

$$Q(x) = \int_x^{\infty} \frac{1}{\sqrt{2\pi}} e^{-\frac{z^2}{2}} dz = \text{Erfc}(x) \quad (\text{EQ. A1})$$

$$\text{Erf}(x) = \int_{-\infty}^x \frac{1}{\sqrt{2\pi}} e^{-\frac{z^2}{2}} dz$$

The probability of a given PAR occurring within a given discrete range $|\Delta|$ is presented in Equation A2.

$$P(x_{\Delta}) = \{1 - [1 - 2\{Q(x) - Q(x + \Delta)\}]^N\} \{[1 - 2Q(x + \Delta)]^N\} \quad (\text{EQ. A2})$$

The first term on the right represents the probability of one or more samples having a value that falls within the range of $|\Delta|$ given a block of N samples. The second term on the right gives the probability that the value that fell within $|\Delta|$ is actually the peak value for an N block of data (i.e., no other values exceed this value). We now concentrate on the first

Application Note 9718

term on the right. As the interval $|\Delta|$ becomes vanishingly small, the quantity $Q(x) - Q(x + \Delta)$ also becomes arbitrarily small. We can expand the expression $[1 - 2\{Q(x) - Q(x + \Delta)\}]^N$ using the binomial expansion and for a sufficiently small interval, it will suffice to keep only the first two terms of the expansion. This allows us to closely approximate the expression as $[1 - 2\{Q(x) - Q(x + \Delta)\}]^N \approx 1 - 2N\{Q(x) - Q(x + \Delta)\}$. We can then rewrite Equation A2 as shown in Equation A3.

$$P(x_\Delta) = 2N\{Q(x) - Q(x + \Delta)\} [1 - 2Q(x)]^N. \quad (\text{EQ. A3})$$

Referring to Equation A3, we can transform the difference into a derivative by dividing and multiplying by the quantity Δ and using the well known limit theory. We can then rewrite Equation A3 as shown in Equation A4.

$$P(x) = 2NQ'(x)[1 - 2Q(x)]^N \Delta \quad (\text{EQ. A4})$$

where $Q'(x) = \frac{d}{dx}(Q(x)) = \frac{d}{dx}(\text{Erfc}(x)) = -\frac{d}{dx}(1 - \text{Erf}(x))$ is given as

$$Q'(x) = \frac{1}{\sqrt{2\pi}} e^{-\frac{x^2}{2}}. \quad (\text{EQ. A5})$$

We can rewrite Equation A4 as a probability density by substituting in Equation A5, resulting in Equation A6 and the corresponding plot of Figure 2.

$$P(x) = \frac{2N}{\sqrt{2\pi}} e^{-\frac{x^2}{2}} [1 - 2Q(x)]^N \Delta. \quad (\text{EQ. A6})$$

We can replace the variable Δ in Equation A5 with a wider interval B , which is conceptually invoking the rectangular integration approximation rule. As long as the interval is reasonable, we will suffer little loss in precision. Thus, we end up with a final expression as shown in Equation A7.

$$P(x) = \frac{2N}{\sqrt{2\pi}} e^{-\frac{x^2}{2}} [1 - 2Q(x)]^N B. \quad (\text{EQ. A7})$$

where B is the interval of interest about the point x .

All Intersil semiconductor products are manufactured, assembled and tested under **ISO9000** quality systems certification.

Intersil semiconductor products are sold by description only. Intersil Corporation reserves the right to make changes in circuit design and/or specifications at any time without notice. Accordingly, the reader is cautioned to verify that data sheets are current before placing orders. Information furnished by Intersil is believed to be accurate and reliable. However, no responsibility is assumed by Intersil or its subsidiaries for its use; nor for any infringements of patents or other rights of third parties which may result from its use. No license is granted by implication or otherwise under any patent or patent rights of Intersil or its subsidiaries.

For information regarding Intersil Corporation and its products, see web site www.intersil.com